

Gx-390 Electrical Layout 20K (Model 1)

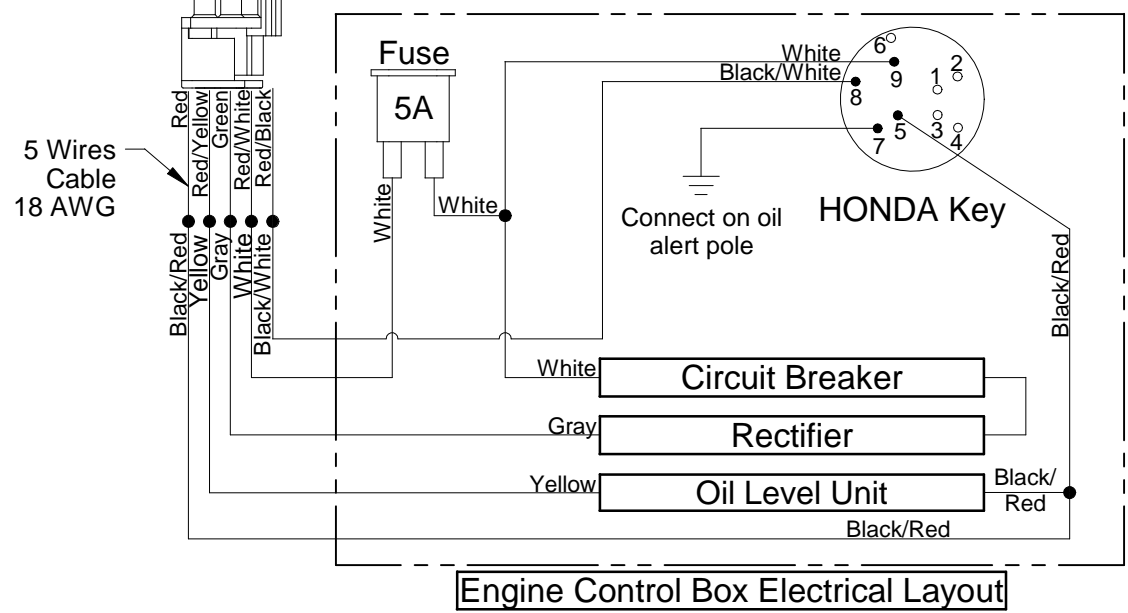

Engine Male Connector

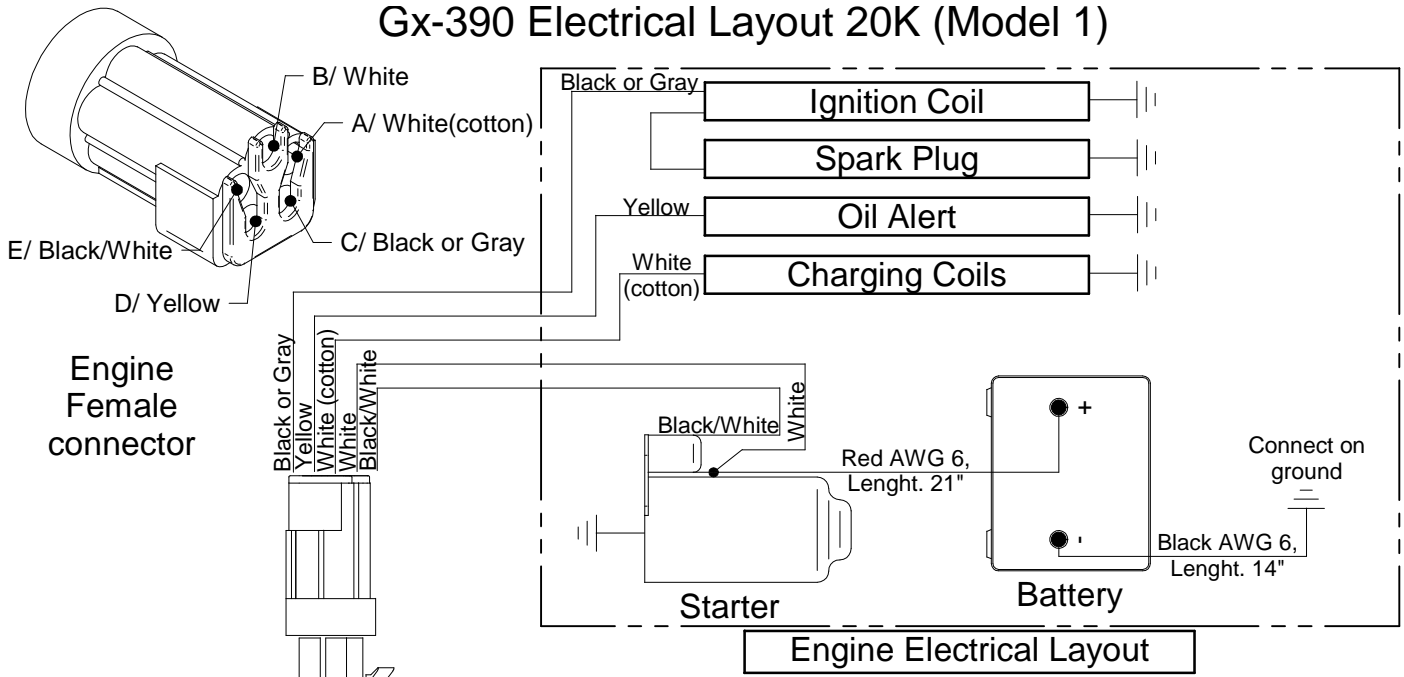
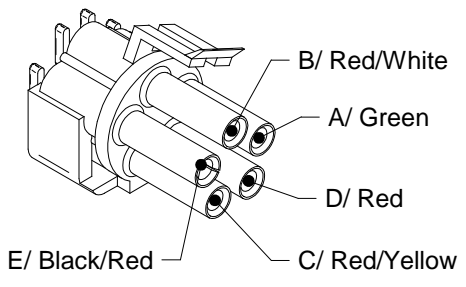

Hydraulic layout

#	Description
1	Cylinder 20" X 4"
2	Valve BM-30
3	hydraulic pump 6 GPM
4	Filter
5	Counterbalance valve
6	Pressure gauge

